

# TM 11-5820-765-12

DEPARTMENT OF THE ARMY TECHNICAL MANUAL

---

OPERATOR AND ORGANIZATIONAL MAINTENANCE MANUAL

## POWER SUPPLIES

### PP-4763/GRC

### AND PP-4763A/GRC

This copy is a reprint which includes current pages from Changes 3 and 4.

---

HEADQUARTERS, DEPARTMENT OF THE ARMY

28 OCTOBER 1968

## **WARNING**

### **DANGEROUS VOLTAGES EXIST IN THE EQUIPMENT**

#### **DON'T TAKE CHANCES!**

Low-voltage, high-amperage current is present at output connections and at connections inside the equipment. Do not touch connections or remove the cabinet cover until equipment is removed from power source. Reenergize the power supply before connecting or disconnecting the equipment to be powered and before performing any maintenance.

Be careful when working on the 115- or 230-volt ac line connections. Serious injury or DEATH may result from contact with these terminals.

Change }  
No. 4 }HEADQUARTERS  
DEPARTMENT OF THE ARMY  
Washington, DC, 26 November 1983

# OPERATOR'S AND ORGANIZATIONAL MAINTENANCE MANUAL

## POWER SUPPLIES PP-4763/GRC (NSN 5820-00-937-7690) AND PP-4763A/GRC (NSN 5820-00-113-9768)

TM 11-5820-765-12, 28 October 1968, is changed as follows:

The title of the manual is changed as shown above.

*Page 1-1.* Paragraph 1-1 is superseded as follows:

### 1-1. Scope

*a.* This manual describes Power Supplies PP-4763/GRC and PP-4763A/GRC (fig. 1-1) and provides instructions for their installation, operation, and maintenance. It includes instructions for cleaning and inspection of the equipment, and touchup painting instructions.

*b.* The Components of End Items List is contained in appendix B.

*c.* The Maintenance Allocation Chart (MAC) appears in appendix C.

*d.* Appendix C is current as of 15 October 1968.

*Page 1-1.* Paragraph 1-2 is superseded as follows:

### 1-2. Consolidated Index of Army Publications and Blank Forms

Refer to the latest issue of DA Pam 310-1 to determine whether there are new editions, changes or additional publications pertaining to the equipment.

*Page 1-1.* Paragraphs 1-3, 1-3.1 and 1-3.2 are superseded as follows:

### 1-3. Maintenance Forms, Records, and Reports

*a. Reports of Maintenance and Unsatisfactory Equipment.* Department of the Army forms and procedures used for equipment maintenance will be those prescribed by TM 38-750, The Army Maintenance Management System.

*b. Report of Packaging and Handling Deficiencies.* Fill out and forward SF 364 (Report of Discrepancy (ROD)) as prescribed in AR 735-11-2/DLAR 4140.55/NAVMATINST 4355.73A/AFR 400-54/MCO 4430.3F.

*c. Discrepancy in Shipment Report (DISREP) (SF 361).* Fill out and forward Discrepancy in Shipment Report (DISREP) (SF 361) as prescribed in AR 55-38/NAVSUPINST 4610.33C/AFR 75-18/MCO P4610.19D/DLAR 4500.15.  
**1-3.1. Reporting Errors and Recommending Improvements**

You can help improve this manual. If you find any mistakes or if you know of a way to improve the procedures, please let us know. Mail your letter or DA Form 2028 (Recommended Changes to Publications and Blank Forms), direct to: Commander, US Army Communications-Electronics Command and Fort Monmouth, ATTN: DRSEL-ME-MP, Fort Monmouth, New Jersey 07703. In either case, a reply will be furnished direct to you.

### 1-3.2. Reporting Equipment Improvement Recommendations (EIR)

If your Power Supply needs improvement, let us know. Send us an EIR. You, the user, are the only one who can tell us what you don't like about your equipment. Let us know why you don't like the design. Put it on an SF 368 (Quality Deficiency Report). Mail it to Commander, US Army Communications-Electronics Command and Fort Monmouth, ATTN: DRSEL-ME-MP, Fort Monmouth, New Jersey 07703. We'll send you a reply.

*Page 1-1.* Paragraphs 1-3.3 and 1-3.4 are added as follows:

### 1-3.3. Administrative Storage

Administrative Storage of equipment issued to and used by Army activities will have preventive maintenance performed in accordance with the PMCS charts before storing. When removing the equipment from administrative storage the PMCS should be performed to assure operational readiness. Disassembly and repacking of equipment for shipment or limited storage are covered in Chapter 5.

\*This change supersedes change 2, 13 Sept 1978.

### 1-3.4. Destruction of Army Electronics Materiel

Destruction of Army electronics materiel to prevent enemy use shall be in accordance with TM 750-244-2.

*Page 1-2.* Add paragraph 1-7 after paragraph 1-6.

### 1-7. Items Comprising an Operable Equipment

Power Supply PP-4763/GRC (NSN 5820-00-937-7690) or Power Supply PP-4763A/GRC (NSN 5820-00-113-9768) is an operable equipment.

*Page 2-1.* Add the following CAUTION after subparagraph 2-1b(2):

### **CAUTION**

Due to the weight of Power Supplies PP-4763/GRC and PP-4763A/GRC, two people are required for ease of handling, and to avoid possible injury to personnel, or damage to equipment.

Subparagraph 2-2b. The second and third sentences are superseded as follows: If a packing slip is not available, check the equipment against paragraph 1-7. Report all discrepancies in accordance with AR 735-11-2.

*Page 3-1.* Chapter 3 is superseded as follows:

## **CHAPTER 3 OPERATOR'S MAINTENANCE**

### 3-1. Scope of Operator's Maintenance

The maintenance duties assigned to the operator of the power supply are listed below together with a reference to the table or paragraph covering the specific maintenance function.

*a.* Operator's preventive maintenance checks and services (table 3-1).

*b.* Cleaning (para 3-3b).

Paragraph 3-2 is deleted.

### 3-3. Operator's Preventive Maintenance

#### **NOTE**

Refer to TM 750-244-2 for proper procedures for destruction of this equipment to prevent enemy use.

*a.* Operator/crew preventive maintenance is the systematic care, servicing and inspection of equipment to prevent the occurrence of trouble, to reduce downtime, and to maintain equipment in serviceable condition. To be sure that your equipment is always ready for your mission, you must do scheduled preventive maintenance checks and services (PMCS).

(1) BEFORE OPERATION, perform your B PMCS to be sure that your equipment is ready to go.

(2) DURING OPERATION, perform your D PMCS. This should help you to spot small troubles before they become big problems.

(3) When an item of equipment is reinstalled after removal, for any reason, perform the necessary B PMCS to be sure the item meets the readi-

ness reporting criteria.

(4) Use the ITEM NO. column in the PMCS table to get the number to be used in the TM ITEM NO. column on DA Form 2404 (Equipment Inspection and Maintenance Worksheet) when you fill out the form.

*b.* Routine checks like CLEANING, PRESERVATION, DUSTING, WASHING, CHECKING FOR FRAYED CABLES, STOWING ITEMS NOT IN USE, COVERING UNUSED RECEPTACLES, CHECKING FOR LOOSE NUTS AND BOLTS AND CHECKING FOR COMPLETENESS are not listed as PMCS checks. They are things that you should do any time you see they must be done. If you find a routine check like one of those listed in your PMCS, it is because other operators reported problems with this item.

#### **NOTE**

When you are doing any PMCS or routine checks, keep in mind the warnings and cautions.

#### **WARNINGS**

- Be careful when working on the 115- or 230-volt ac line connections. Serious injury or DEATH may result from contact with these terminals.

Low-voltage, high amperage current is present at output connections and at connections inside equipment. Do not touch connections or remove cabinet cover until equipment is removed from power source. Reenergize power supply before performing any maintenance.

- Adequate ventilation should be provided

while using TRICHLOROTRIFLUOROETHANE. Prolonged breathing of vapor should be avoided. The solvent should not be used near heat or open flame; the products of decomposition are toxic and irritating. Since TRICHLOROTRIFLUOROETHANE dissolves natural oils, prolonged contact with skin should be avoided. When necessary, use gloves which the solvent cannot penetrate. If the solvent is taken internally, consult a physician immediately.

- Compressed air is dangerous and can cause serious bodily harm if protective means or methods are not observed to prevent a chip or particle (of whatever size) from being blown into the eyes or unbroken skin of the operator or other personnel. Goggles must be worn at all times while cleaning with compressed air. Compressed air shall not be used for cleaning purposes except where reduced to less than 29 pounds per square inch gage (psig) and then only with effective chip guarding and personnel protective equipment. Do not use compressed air to dry parts when trichlorotrifluoroethane has been used.

charts instruct how to perform the required checks and services. Carefully follow these instructions and, if tools are needed or the chart so instructs, get organizational maintenance to do the necessary work.

If your equipment must be in operation all the time, check those items that can be checked and serviced without disturbing operation. Make the complete checks and services when the equipment can be shut down.

c. Deficiencies that cannot be corrected must be reported to higher category maintenance personnel. Records and reports of preventive maintenance must be made in accordance with procedures given in TM 38-750.

**3-4. Operator/Crew Preventive Maintenance Checks and Services (Table 3-1).**

**NOTES**

The checks in the interval column are to be performed in the order listed.

The terms “ready/available” and “mission capable” refer to the same status — Equipment is on hand and is able to perform its combat mission (see TM 38-750).

**NOTES**

The PROCEDURES column in your PMCS

**Table 3-1. Operator/Crew Preventive Maintenance Checks and Services Chart**

Item No.	Interval		Item to be Inspected	Procedures — Check for and have repaired or adjusted as necessary	Equipment is Not Ready/Available If:
	B	D			
1	●		Mission Essential Equipment	Check for completeness and satisfactory condition of the equipment. Report missing items.	Available equipment is insufficient to support the combat mission.
2	*	●	Power Supply	Turn power supply on. Check output voltage and current.	Output voltage does not read between 27 and 29 volts.
3	●	●	Cooling Fan	Check cooling fan operation and see that air flows through the louvers on top and bottom of power supply.	Fan does not operate <b>NOTE</b> Some later model power supplies may not have a fan.

\*Do this check before each deployment to a mission location. This will permit any existing problems to be corrected before the mission starts. The check does not need to be done again until redeployment.

Page 4-1. Chapter 4 is superseded as follows:

**CHAPTER 4**

**ORGANIZATIONAL MAINTENANCE**

**4-1. Scope of Organizational Maintenance**

a. This chapter contains instructions covering organizational maintenance for the power supply. It includes instructions for performing preventive and periodic maintenance services and repair functions to be accomplished by the organizational repair personnel.

b. Organizational maintenance of the power supply includes:

(1) Preventive maintenance checks and services (table 4-1).

(2) Touchup painting (para 4-4).

**4-2. Test Equipment, Tools, and Materials Required**

The test equipment, tools, and materials required for organizational maintenance of the power supply are listed below:

a. *Test Equipment.* Multimeter AN/URM-105.

b. *Tools.* Tool Kit, Electronic Equipment TK-101/G.

c. *Materials.*

(1) Trichlorotrifluoroethane. (NSN 6850-00-105-3084).

(2) Cleaning cloth.

(3) Fine sandpaper (supplied with Tool Kit, Electronic Equipment TK-101/G).

(4) Cotton swab sticks.

(5) Silicone (NSN 6850-00-880-7616).

**4-3. Organizational Preventive Maintenance**

Organizational preventive maintenance procedures are designed to help maintain equipment in serviceable condition. They include items to be

checked and how to check them. These checks and services, described in table 4-1, outline inspections that are to be made at specific monthly (M) intervals. Accomplish routine checks as described in paragraph 3-3b including WARNINGS and NOTES.

**Table 4-1. Organizational Preventive Maintenance Checks and Services Chart**

M - Monthly

Item No.	Interval	Item to be Inspected	Procedures
	M		
1	•	output Voltage	Check output voltage. Adjust to read between 27 to 29 volts, if required.

**4-4. Touchup Painting**

Remove rust and corrosion from metal surfaces by lightly sanding them with fine sandpaper. Brush two thin coats of paint (Enamel, Semigloss, Olive Drab NSN 8010-00-844-8088) on the bare metal to protect it from further corrosion. Refer to the applicable cleaning and refinishing practices specified in TB 43-0118 and the painting supplies available for field use in SB 11-573.

Page 5-1. Section II, paragraphs 5-3 and 5-4 are superseded as follows:

**5-3. Authority for Demolition**

Refer to paragraph 1-3.4. Destruction of Army Electronics Materiel.

**5-4. Paragraph 5-4 deleted.**

Page A-1. Appendix A is superseded as follows:

**APPENDIX A**

**REFERENCES**

The following is a list of applicable references that are available to the operator and organizational repairman of the power supply.

AR 55-38 Reporting of Transportation Discrepancies in Shipments (Reports Control Symbol (MTMTS-54)).

AR 735-11-2 Reporting of Item and Packaging Discrepancies.

## APPENDIX A

### REFERENCES (CONT'D)

---

DA Pam 310-1 SB 11-573	Consolidated Index of Army Publications and Blank Forms. Painting and Preservation of Supplies Available for Field Use for Electronics Command Equipment.
SB 38-100	Preservation, Packaging, Packing and Marking Materials, Supplies, and Equipment Used by the Army.
SC 5180-91-CL-R13	Tool Kit, Electronic Equipment TK-101/G (NSN 5180-00- 064-5178).
TB 43-0118	Field Instructions for Painting and Preserving Electronics Command Equipment Including Camouflage pattern Painting of Electrical Equipment Shelter.
TM 11-6625-203-12	Operator's and Organizational Maintenance Manual: Multi- meter AN/URM-105 and AN/URM-105C (Including Multi- meter ME-77/U and ME-77C/U).
TM 38-750 TM 750-244-2	The Army Maintenance Management System (TAMMS). Procedures for Destruction of Electronics Materiel to Prevent Enemy Use.

*Page B-1.* Appendix B is superseded as follows:

## APPENDIX B

### COMPONENTS OF END ITEM LIST

---

#### Section I. INTRODUCTION

##### **B-1. Scope**

This appendix lists integral components of and basic issue items for the PP-4763/GRC to help you inventory items required for safe and efficient operation.

##### **B-2. General**

This Components of End Item List is divided into the following sections:

*a. Section II. Integral Components of the End Item.* These items, when assembled, comprise the PP-4763/GRC and must accompany it whenever it is transferred or turned in. The illustrations will help you identify these items.

*b. Section II. Basic Issue Items.* These are the minimum essential items required to place the PP-4763/GRC in operation, to operate it, and to perform emergency repairs. Although shipped separately packed they must accompany the PP-4763/GRC during operation and whenever it is transferred between accountable officers. The illustrations will assist you with hard-to-identify items.

This manual is your authority to requisition replacement BII, based on TOE/MTOE authorization of the end item.

##### **B-3. Explanation of Columns**

*a. Illustration.* This column is divided as follows:

(1) *Figure number.* Indicates the figure number of the illustration on which the item is shown.

(2) *Item number.* The number used to identify item called out in the illustration.

*b. National Stock Number.* Indicates the National stock number assigned to the item and which will be used for requisitioning.

*c. Description.* Indicates the Federal item name and, if required, a minimum description to identify the item. The part number indicates the primary number used by the manufacturer, which controls the design and characteristics of the item by means of its engineering drawings, specifications, standards, and inspection requirements to identify an item or range of items. Following the part num-

her, the Federal Supply Code for Manufacturers (FSCM) is shown in parentheses.

d. *Location.* The physical location of each item listed is given in this column. The lists are designed to inventory all items in one area of the major item before moving on to an adjacent area.

e. *Usable on Code.* Not applicable.

f. *Quantity Required (Qty Reqd).* This column lists the quantity of each item required for a complete major item.

g. *Quantity.* This column is left blank for use during an inventory. Under the Rcvd column, list the quantity you actually receive on your major item. The Date columns are for your use when you inventory the major item.

**SECTION II INTEGRAL COMPONENTS OF END ITEM**

(1) ILLUSTRATION		(2) NATIONAL STOCK NUMBER	(3) DESCRIPTION PART NUMBER (FSCM)	(4) LOCATION	(5) USABLE ON CODE	(6) QTY REQD	(7) QUANTITY	
(A) FIG NO.	(B) ITEM NO.						RCVD	DATE
1-1	A	5820-00-937-7690	POWER SUPPLY PP-4763/GRC or					
1-1	B	5820-00-113-9768	POWER SUPPLY PP-4763A/GRC					

**SECTION III BASIC ISSUE ITEMS**

(1) ILLUSTRATION		(2) NATIONAL STOCK NUMBER	(3) DESCRIPTION PART NUMBER (FSCM)	(4) LOCATION	(5) USABLE ON CODE	(6) QTY REQD	(7) QUANTITY	
(A) FIG NO.	(B) ITEM NO.						RCVD	DATE
			<u>PUBLICATIONS</u> TM 11-5820-765-12					



By Order of the Secretary of the Army:

Official:

ROBERT M. JOYCE  
*Major General, United States Army*  
*The Adjutant General*

JOHN A. WICKHAM JR.  
*General, United States Army*  
*Chief of Staff*

DISTRIBUTION:

To be distributed in accordance with DA Form 12-51, Operator's Maintenance requirements for PP-4763/GRC.

CHANGE }  
No. 3 }

HEADQUARTERS  
DEPARTMENT OF THE ARMY  
WASHINGTON, DC, 18 September 1980

**OPERATOR'S AND ORGANIZATIONAL MAINTENANCE MANUAL  
POWER SUPPLIES PP-4763/GRC (NSN 5820-00-937-7690)  
AND  
PP-4763A/GRC (NSN 5820-00-113-9768)**

This Change current as of 15 April 1980.

TM 11-5820-765-12, 28 October 1968, is changed  
as follows:

Page C-1. Appendix C is superseded as follows:

**APPENDIX C  
MAINTENANCE ALLOCATION**

---

**Section I. INTRODUCTION**

**C-1. General**

This appendix provides a summary of the maintenance operations for PP-4763/GRC and PP-4763A/GRC. It authorizes categories of maintenance for specific maintenance functions on repairable items and components and the tools and equipment required to perform each function. This appendix may be used as an aid in planning maintenance operations.

**C-2. Maintenance Function**

Maintenance functions will be limited to and defined as follows:

*a. Inspect* To determine the serviceability of an item by comparing its physical, mechanical, and/or electrical characteristics with established standards through examination.

*b. Test.* To verify serviceability and to detect incipient failure by measuring the mechanical or electrical characteristics of an item and comparing those characteristics of an item and comparing those characteristics with prescribed standards.

*c. Service.* Operations required periodically to keep an item in proper operating condition, i.e., to clean (decontaminate), to preserve, to drain, to paint, or to replenish fuel, lubricants, hydraulic fluids, or compressed air supplies.

*d. Adjust* To maintain, within prescribed limits, by bringing into proper or exact position,

or by setting the operating characteristics to the specified parameters.

*e. Align.* To adjust specified variable elements of an item to bring about optimum or desired performance.

*f. Calibrate.* To determine and cause corrections to be made or to be adjusted on instruments or test measuring and diagnostic equipments used in precision measurement. Consists of comparisons of two instruments, one of which is a certified standard of known accuracy, to detect and adjust any discrepancy in the accuracy of the instrument being compared.

*g. Install.* The act of emplacing, seating, or fixing into position an item, part, module (component or assembly) in a manner to allow the proper functioning of the equipment or system.

*h. Replace.* The act of substituting a serviceable like type part, subassembly, or module (component or assembly) for an unserviceable counterpart.

*i. Repair.* The application of maintenance services (inspect, test, service, adjust, align, calibrate, replace) or other maintenance actions (welding, grinding, riveting, straightening, facing, remachining, or resurfacing) to restore serviceability to an item by correcting specific damage, fault, malfunction, or failure in a part,

subassembly, module (component or assembly), end item, or system.

*j. Overhaul.* That maintenance effort (service/action) necessary to restore an item to a completely serviceable/operational condition as prescribed by maintenance standards (i.e., DMWR) in appropriate technical publications. Overhaul is normally the highest degree of maintenance performed by the Army. Overhaul does not normally return an item to like new condition.

*k. Rebuild.* Consists of those services/actions necessary for the restoration of unserviceable equipment to a like new condition *in* accordance with original manufacturing standards. Rebuild is the highest degree of materiel maintenance applied to Army equipment. The rebuild operation includes the act of returning to zero those age measurements (hours, miles, etc.) considered in classifying Army equipments/components.

### **C-3. Column Entries**

*a. Column 1, Group Number.* Column 1 lists group numbers, the purpose of which is to identify components, assemblies, subassemblies, and modules with the next higher assembly.

*b. Column 2, Maintenance Category.* Column 2 contains the noun names of components, assemblies, subassemblies, and modules for which maintenance is authorized.

*c. Column 3, Maintenance Functions.* Column 3 lists the functions to be performed on the item listed in column 2. When items are listed without maintenance functions, it is solely for purpose of having the group numbers in the MAC and RPSTL coincide.

*d. Column 4, Maintenance Category* Column 4 specifies, by the listing of a "work time" figure in the appropriate subcolumn(s), the lowest level of maintenance authorized to perform the function listed in column 3. This figure represents the active time required to perform that maintenance function at the indicated category of maintenance. If the number or complexity of the tasks within the listed maintenance function vary at different maintenance categories, appropriate "work time" figures will be shown for each category. The number of task-hours specified by the "work time" figure represents the average time required to restore an item (assembly, subassembly, component, module,

end item or system) to a serviceable condition under typical field operating conditions. This time includes preparation time, troubleshooting time, and quality assurance/quality control time in addition to the time required to perform the specific tasks identified for the maintenance functions authorized in the maintenance allocation chart. Subcolumns of column 4 are as follows:

- C - Operator/Crew
- O - Organizational
- F - Direct Support
- H - General Support
- D - Depot

*e. Column 5, Tools and Equipment.* Column 5 specifies by code, those common tool sets (not individual tools) and special tools, test, and support equipment required to perform the designated function.

*f. Column 6, Remarks.* Column 6 contains an alphabetic code which leads to the remarks in section IV, Remarks, which is pertinent to the item opposite the particular code.

### **C-4. Tool and Test Equipment Requirements (Sec. III)**

*a. Tool or Test Equipment Reference Code.* The numbers in this column coincide with the numbers used in the tools and equipment column of the MAC. The numbers indicate the applicable tool or test equipment for the maintenance functions.

*b. Maintenance Category.* The codes in this column indicate the maintenance category allocated the tool or test equipment.

*c. Nomenclature.* This column lists the noun name and nomenclature of the tools and test equipment required to perform the maintenance functions.

*d. National/NATO Stock Number.* This column lists the National/NATO stock number of the specific tool or test equipment.

*e. Tool Number.* This column lists the manufacturer's part number of the tool followed by the Federal Supply Code for manufacturers (5-digit) in parentheses.

### **C-5. Remarks (Sec. IV)**

*a. Reference Code.* This code refers to the appropriate item in section II, column 6.

*b. Remarks.* This column provides the required explanatory information necessary to clarify items appearing in section II.

**SECTION II MAINTENANCE ALLOCATION CHART  
FOR  
POWER SUPPLIES PP-4763/GRC AND PP-4763A/GRC**

(1) GROUP NUMBER	(2) COMPONENT/ASSEMBLY	(3) MAINTENANCE FUNCTION	(4) MAINTENANCE CATEGORY					(5) TOOLS AND EQPT.	(6) REMARKS
			C	O	F	H	D		
00	POWER SUPPLIES PP-4763/GRC AND PP-4763A/GRC	Inspect		0.3					
		Test	0.2						
		Test		0.2					1
		Test			0.5				5 thru 8
		Test				0.5			5 thru 9
		Service		0.3					2
		Adjust		0.2					2
		Install		0.3					2
		Repair			0.5				3,4
		Overhaul					1.0		3,4 3 thru 10
01	CIRCUIT CARD ASSEMBLY PC101 (PP-4763/GRC) A1 (PP-4763A/GRC)	Inspect			0.3				
		Test				0.3			5 thru 9
		Replace			0.3				3,4
		Repair				0.5			3,4
		Overhaul					1.0		3 thru 10

SECTION III TOOL AND TEST EQUIPMENT REQUIREMENTS  
FOR

POWER SUPPLIES PP-4763/GRC AND PP-4763A/GRC

TOOL OR TEST EQUIPMENT REF CODE	MAINTENANCE CATEGORY	NOMENCLATURE	NATIONAL/NATO STOCK NUMBER	TOOL NUMBER
1	0	MULTIMETER AN/URM-105	6625-00-884-1758	
2	0	TOOL KIT, ELECTRONIC EQUIPMENT TK-101/G	5180-00-064-5178	
3	F,H,D	TOOL KIT, ELECTRONIC EQUIPMENT TK-100/G	5180-00-605-0079	
4	F,H,D	TOOL KIT, ELECTRONIC EQUIPMENT TK-105/G	5180-00-610-8177	
5	F,H,D	MULTIMETER TS-352B/U	6625-00-553-0142	
6	F,H,D	VOLTMETER, ELECTRONIC AN/USM-98( )	6625-00-753-2115	
7	F,H,D	TRANSFORMER, VARIABLE POWER TF-171/USM	6120-00-503-0632	
8	F,H,D	VOLTMETER, ELECTRONIC ME-30( )/U (AN/URM-145 MAY BE USED)	6625-00-643-1670	
9	H,D	OSCILLOSCOPE AN/USM-281A (AN/USM-140 MAY BE USED)	6625-00-228-2201	
10	D	KNIFE SWITCH; SINGLE POLE, 60 AMPERE		

SECTION IV. REMARKS

REFERENCE CODE	REMARKS
A	OPERATIONAL TESTS ONLY.
B	OPERATIONAL TESTS AND CIRCUIT CONTINUITY ONLY.
C	DIODE, METER, RECTIFIER, AND CAPACITOR CHECKS ONLY.
D	VOLTAGE ADJUSTMENTS.
E	REPAIR BY REPLACEMENT OF PRINTED WIRING ASSEMBLY AND BY REPLACEMENT OF FREE STANDING PIECE PARTS.

By Order of the Secretary of the Army:

E. C. MEYER  
*General, United States Army*  
*Chief of Staff*

Official:

J. C. PENNINGTON  
*Major General, United States Army*  
*The Adjutant General*

**DISTRIBUTION:**

To be distributed in accordance with DA Form 12-51, Operator maintenance requirements for PP-4763/GRC.

TECHNICAL MANUAL }  
 NO. 11-5820-765-12 }

HEADQUARTERS  
 DEPARTMENT OF THE ARMY  
 WASHINGTON, D.C., 28 October 1968

**Operator and Organizational Maintenance Manual**  
**POWER SUPPLIES PP-4763/GRC AND PP-4763/GRC**

	Paragraph	Page
<b>CHAPTER 1.</b>	<b>INTRODUCTION</b>	
<b>Section I.</b>	General	
	Scope-----1-1	1-1
	Indexes of publications-----1-2	1-1
	Forms and records ----- 1-3	1-1
<b>II.</b>	Description and data	
	Purpose and use-----1-4	1-1
	Technical characteristics -----1-5	1-1
	Description of Power Supplies	
	PP-4763/GRC and	
	PP-4768A/GRC-----1-6	1-2
<b>CHAPTER 2.</b>	<b>INSTALLATION AND OPERATING INSTRUCTIONS</b>	
<b>Section I.</b>	Service upon receipt of equipment	
	Unpacking-----2-1	2-1
	Checking unpacked equipment-----2-2	2-1
<b>II.</b>	Installation instructions	
	Suitable location-----2-3	2-3
	Connections-----2-4	2-3
<b>III.</b>	Operation	
	Operating control and indicators-----2-5	2-5
	Preliminary operating procedure-----2-6	2-5
	Operating procedure-----2-7	2-5
	Stopping procedure ----- 2-8	2-5
<b>CHAPTER 3.</b>	<b>OPERATOR'S MAINTENANCE</b>	
	Scope of operator's maintenance----- 3-1	3-1
	Materials required-----3-2	3-1
	Operator's preventive maintenance-----3-3	3-1
	Operator's preventive maintenance checks and services periods-----3-4	3-1
	Operator's daily preventive maintenance checks and services chart----3-5	3-1
	Operator's weekly preventive maintenance checks and services chart.-3-6	3-2
	Cleaning-----3-7	3-2
<b>CHAPTER 4.</b>	<b>ORGANIZATIONAL MAINTENANCE</b>	
	Scope of Organizational maintenance-----4-1	4-1
	Test equipment tools and materials required----- 4-2	4-1
	Organizational monthly maintenance-----4-3	4-1
	Organizational monthly preventive maintenance checks and services	
	chart-----4-4	4-1
	Touchup painting-----4-5	4-2
<b>CHAPTER 5.</b>	<b>SHIPMENT AND LIMITED STORAGE AND DEMOLITION TO PREVENT ENEMY USE</b>	
<b>Section I.</b>	Shipment and limited storage	
	Disassembly and repacking of equipment----- 5-1	5-1
	Repackaging-----5-2	5-1
<b>II.</b>	Demolition of materiel to prevent enemy use	
	Authority for demolition-----5-3	5-1
	Methods of destruction-----5-4	5-1
<b>APPENDIX A.</b>	<b>REFERENCES-----</b>	<b>A-1</b>
<b>B.</b>	<b>BASIC ISSUE ITEMS-----</b>	<b>B-1</b>
<b>C.</b>	<b>MAINTENANCE ALLOCATION-----</b>	<b>C-1</b>



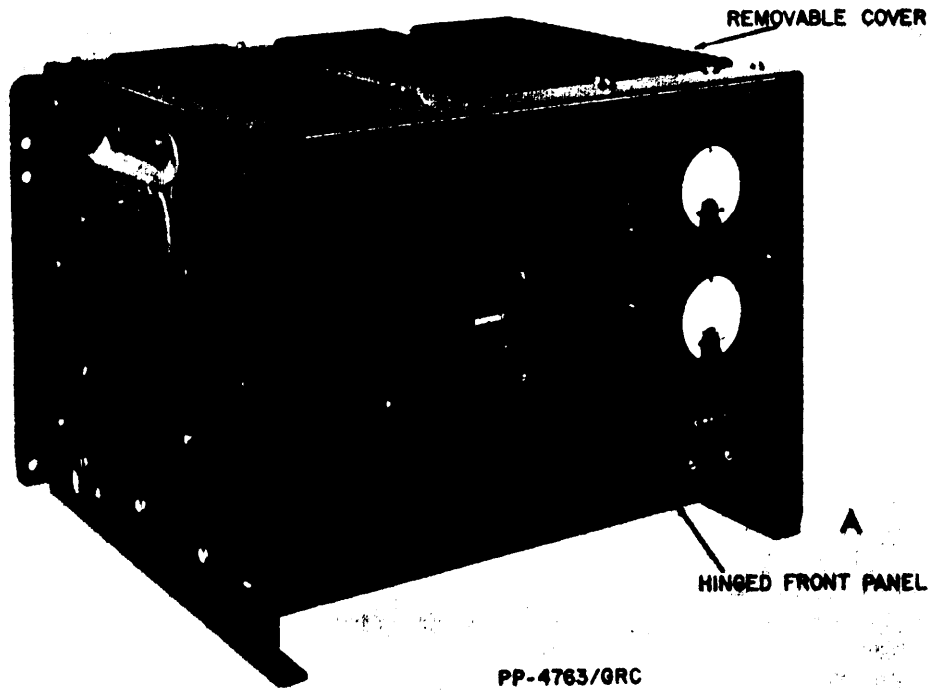

PP-4763/GRC

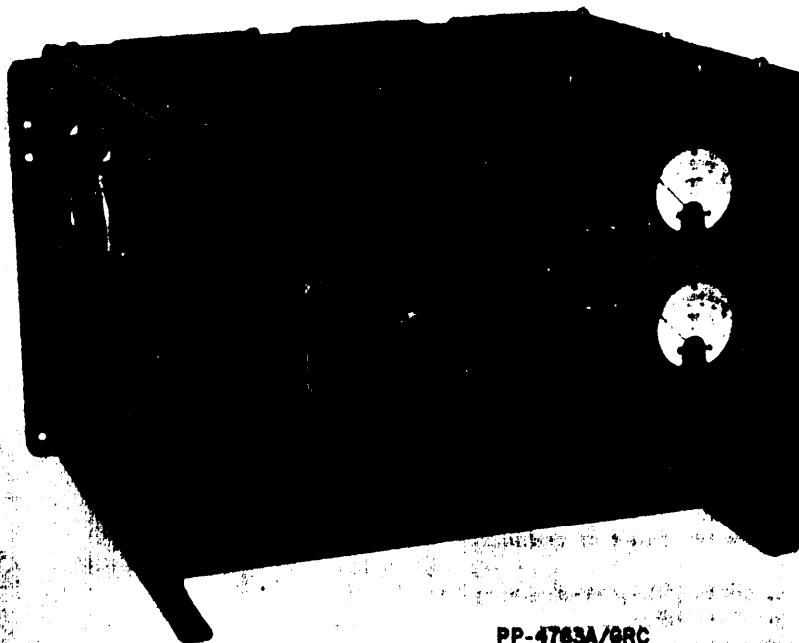

PP-4763A/GRC

TM 55-12-5

Figure 1-1. Power Supplies PP-4763/GRC and PP-4763A/GRC.

# CHAPTER 1

## INTRODUCTION

---

### Section I. GENERAL

#### 1-1. Scope

a. This manual describes Power Supplies PP-4763/GRC and PP-4763A/GRC (fig. 1-1) and provides instructions for their installation, operation, and maintenance. It includes instructions for cleaning and inspection of the equipment, and touchup painting instructions.

b. The basic items issue list (BIIL) appears in appendix B.

c. The maintenance allocation chart (MAC) appears in appendix C.

d. Appendixes B and C are current as of 15 October 1968.

e. Throughout this manual, Power Supplies PP-4763/GRC and PP-4763A/GRC are referred to as *power supply*, except when a specific model is cited.

#### 1-2. Indexes of Publications

a. *DA Pam 310-4*. Refer to the latest issue of DA Pam 310-4 to determine whether there are new editions, changes, or additional publications pertaining to the equipment.

b. *DA Pam 310-7*. Refer to the latest issue of DA Pam 310-7 to determine whether there are modification work orders (MWO'S) pertaining to the equipment.

#### 1-3. Forms and Records

a. *Reports of Maintenance and Unsatisfactory Equipment*. Use equipment forms and records in accordance with instructions given in TM 38-750.

b. *Report of Packing and Handling Deficiencies*. Fill out and forward DD Form 6 (Report of Packaging and Handling Deficiencies) as prescribed in AR 700-58 (Army), NAVSUP Pub 378 (Navy), AFR 71-4 (Air Force), and MCO 4030.29 (Marine Corps).

c. *Discrepancy in Shipment Report (DISREP) (SF 861)*. Fill out and forward Discrepancy in Shipment Report (DISREP) (SF 361) as prescribed in AR 55-38 (Army), NAVSUP Pub 459 (Navy), AFM 75-34 (Air Force), and MCO P4610.19 (Marine Corps).

d. *Report of Equipment Manual Improvements*. Report of errors, omissions, and recommendations for improving this publication by the individual user is encouraged. Reports should be submitted on DA Form 2028 (Recommended Changes to DA Publications) and forwarded direct to Commanding General, U.S. Army Electronics Command, ATTN: AMSEL-ME-NMP-AD, Fort Monmouth, N.J. 07703.

### Section II. DESCRIPTION AND DATA

#### 1-4. Purpose and Use

Power Supply PP-4763/GRC converts 115 volts alternating current (ac) to direct current (dc) at a selected regulated voltage. Power Supply PP-4763A/GRC converts either 115 or 230 volts ac to direct current at a selected regulated voltage. The power supplies function in a similar way; both provide a dc power

source for communication equipment or any type of load with requirements within their voltage and current ratings.

#### 1-5. Technical Characteristics

Power input:

Voltage ----- 115 volts  $\pm 10\%$  at 47 to  
63 cps.(PP-476S/GRC).  
115 volts  $\pm 10\%$  at 47 to

	63 cps, or 230 volts ±10% at 47 to 68 cps (PP-4763A/GRW).
Phase -----	Single.
Current (full load) ----	23 amperes (PP-4763/ GRC).
	23 amperes (PP-4763A/ GRC at 116 volt input).
	11.5 amperes (PP-4763A/ GRC at 280 volt input).
Power output:	
Voltage-----	Variable from 27 to 20 volts dc (28-volt opera- tion).
Current (full load)-----	60 amperes, continuous
Ripple voltage-----	1.0% (root mean square).
Voltage regulation-----	±0.5%
Surrounding operating temperature -----	-4°F (-20°C) to 131°F (55°C).
<i>Meters:</i>	
Output current meter, type MR36W080DCAAR	0 to 80 amperes
Output voltage meter, type MR36W050DCVVR	0 to 60 volts
Solid-state devices	
Semiconductor device, diode:	
PP-4763/GRC-----	16 ea.
PP-4763A/GRC-----	24 ea.
Transistor-----	4 ea.
Semiconductor device, controlled rectifier ---	3 ea.
Rectifier, semiconductor device:	
PP-4763/GRC-----	2 ea.
PP-4763A/GRC-----	None.

**1-6. Description of Power Supplies  
PP4763/GRC and PP4763A/GRC  
(fig. 1-1)**

*a. Physical Description.* The power supply is a self-contained unit in a metal cabinet. PP-4763/GRC is 13½ inches high, 19½ inches wide, and 14¾ inches deep and weighs 120 pounds. PP-4763A/GRC is 13½ inches

high, 19½ inches wide, and 15¼ inches deep and weighs 125 pounds. A hinged front panel and a removable cover provide access to the electrical components. The PP-4763A/GRC is provided with an interlock switch which opens the ac input power circuit when the cover is removed. An input circuit breaker and indicator are mounted on the front panel. A carrying handle is mounted on each side of the metal cabinet. An output voltage adjustment is mounted behind the front panel and can be reached by removing a plate on the outside of the front panel. The PP-4763A/GRC is provided with movable links for converting the equipment for use from a 116-volt ac power source to a 230-volt ac power source. The links can be reached by removing the cover. The sides of the cabinet are flanged on the bottom and at the back for mounting purposes. Venting is provided by air louvers on the bottom and on the top cover of the cabinet. An ac power cable (fig. 2-2) is connected through the rear panel of the power supply. The PP-4763A/GRC is supplied with an ac plug attached to the cable, and the PP4763/GRC is supplied with a cable that has three terminal lugs on each end. Output terminals (dc) with polarity plainly marked are located behind an access plate at the rear panel for connecting the output of the power supply to the equipment being powered (cable not supplied). Also, the PP-4763A/GRC is provided with a dc output receptacle at the rear panel which may be used instead of the output terminals for connecting to equipment being powered.

*b. Solid-State Devices.* The power supplies are solid-state controlled devices. Automatic and continuous regulation of voltage within the limits specified under technical characteristics (para 1-5) is accomplished by a control circuit built into printed card PC101.

## CHAPTER 2

### INSTALLATION AND OPERATING INSTRUCTIONS

---

#### Section I. SERVICE UPON RECEIPT OF EQUIPMENT

##### 2-1. Unpacking

*a. Packaging Data.* When packed for shipment, Power Supply PP-4763/GRC is packed in a 24¾ by 21¾ -by 17¼ -inch wooden box. The volume is 5.4 cubic feet, and the total shipping weight is 193 pounds. The PP-4763A/GRC is packed in a 24¾ -by 22¼ -by 17¼ -inch box. The volume is 5.5 cubic feet, and the total shipping weight is 200 pounds. A typical wooden box and its contents are shown in figure 2-1.

*b. Removing Contents.* Follow the procedure outlined below when unpacking the equipment.

- (1) Remove the nails that secure the plywood box to the wooden base. Lift the box free of the unit and the base.
- (2) Remove the bolts that fasten the power supply to the base.
- (3) Lift the power supply clear of the base.
- (4) Remove the fitted corrugated wrapping paper from the power supply.

##### 2-2. Checking Unpacked Equipment

*a.* Inspect the equipment for damage that may have incurred during shipment. If the equipment has been damaged, refer to paragraph 1-3 for applicable forms and records.

*b.* Check to see that the equipment is complete as listed on the packing slip. If a packing slip is not available, check the equipment against the basic issue items list (appx B). Report all discrepancies in accordance with TM 33-750. The equipment should be placed in service even though a minor assembly or part that does not affect proper functioning is missing.

*c.* Check to see whether the equipment has been modified. If the equipment has been modified, the MWO number will appear on the front panel, near the nomenclature plate. Also, check to see whether all MWO'S current at the time the equipment is placed in use have been applied.

Note. Current MWO's applicable to the equipment are listed in DA PAM 810-7.

*d.* Check the latest issue of DA PAM 310-4 to see whether you have the latest editions of all applicable maintenance literature.

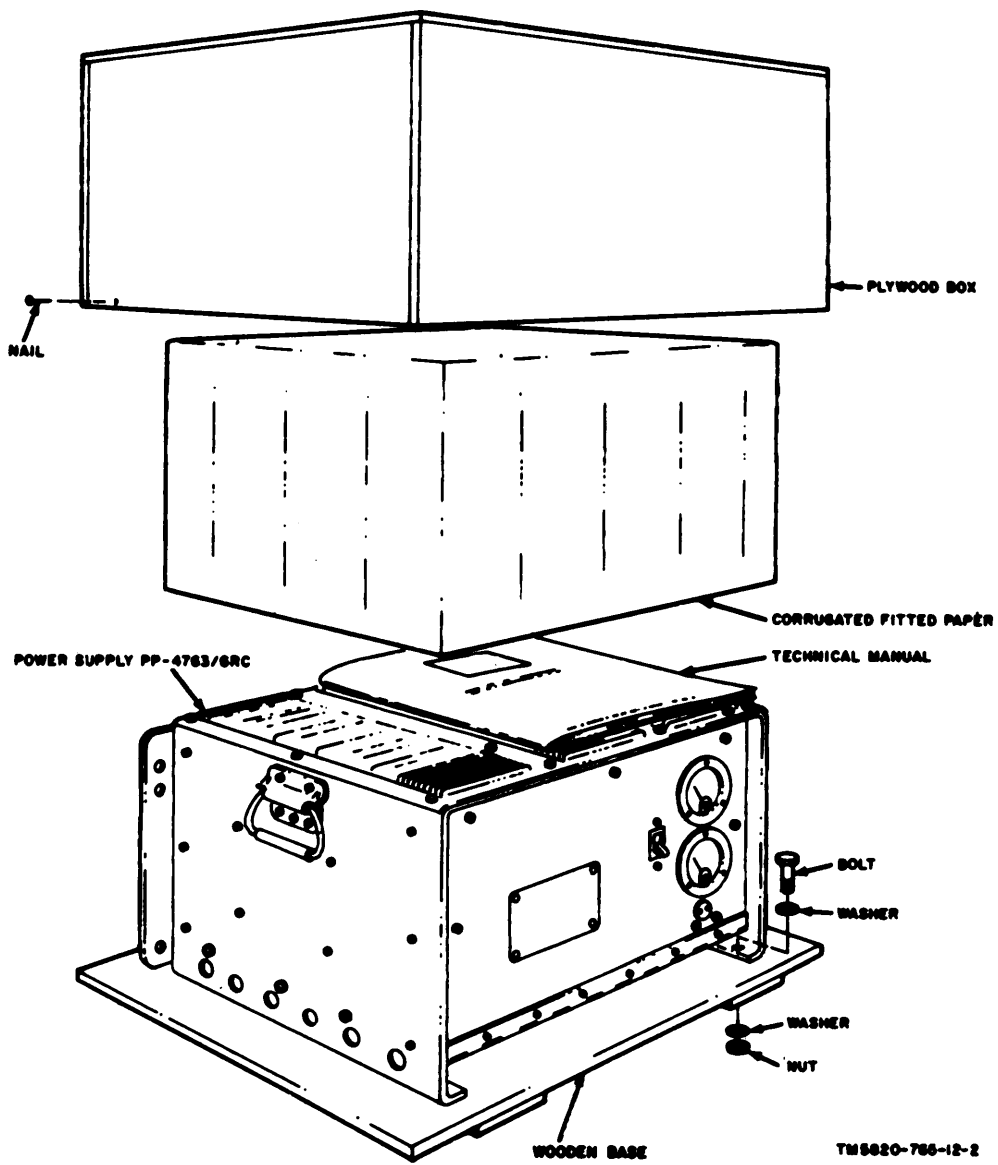

Figure 2-1. Typical packaging.

## Section II. INSTALLATION INSTRUCTIONS

### 2-3. Suitable location

**Caution:** Do not operate the equipment if there is evidence of water inside the cabinet.

The power supply is designed to operate within a sheltered location protected from the elements. It is not designed to operate in rain, snow, or ice, or where surrounding temperature exceeds 55° C<sup>H</sup>.

### 2-4. Connections

(fig. 2-2)

#### Warnings:

1. The metal cabinet must be grounded at all times when it is connected to an ac source. The PP-4763A/GRC is grounded by the ac power cable when the ac power cable is plugged into an ac outlet. The ac power cable supplied with the PP-4763/GRC includes a ground (GRD) wire for this push. The AC ON-OFF switch must be set to OFF before the power supply is connected.

2. Be careful when working on the 115-or 230-volt ac line connections. Serious injury or DEATH may result from contact with them terminals,

3. Low-voltage, high-amperage current is present at output connections and at connections inside the equipment. Do not touch connections or remove the cabinet cover until the equipment is removed from power source. Re-energize the power supply before connecting or disconnecting the equipment to be powered.

a. Turn the AC ON-OFF switch (fig. 1-1) to OFF.

**Caution:** Measure the available ac supply voltage, to determine whether it is 115-or 230-volts ac.

b. Connect the three-wire, ac power cable to a single-phase, 115-volt, 50- to 60-cps source

when using the PP-4763/GRC. Connect the power cable to either a single-phase 115-volt, 50- to 60-cps source, or a single-phase, 230-volt, 50- to 60-cps source when using the PP4763A/GRC. After determining which power source will be used, secure the ac input links in the correct position for the selected input power as illustrated in figure 2-2. For 115-volt power, secure the links as shown in figure 2-2; for 230-volt power, secure the links as shown in figure 2-2. Note that in the 230-volt position, both links are fastened (in parallel) across the two center terminals and secured. A connector is mounted on the power cable to connect the PP-4763A/GRC to the ac power supply; the power cable for the PP4768/GRC maybe connected directly to the ac power supply as follows:

(1) Connect the white wire to the grounded ac terminal.

(2) Connect the black wire to the ungrounded ac terminal.

(3) Connect the GRD wire to a good earth ground.

c. Remove the rear panel access plate to expose the dc output terminals (fig. 2-2).

**Caution:** Be sure to observe correct polarity; for example (+) output terminal to (+) load terminal; (-) output terminal to (-) load terminal.

d. Connect two dc leads with ¼-inch lugs capable of carrying 50-ampere current (or the current requirements of the load connected) to the power supply output terminals. The PP-4763A/GRC is provided with dc output receptacle J1 at the rear panel (fig. 2-2), and either the output terminals or output receptacle J1 may be used.

e. Replace the access panel and tighten the cable clamps.

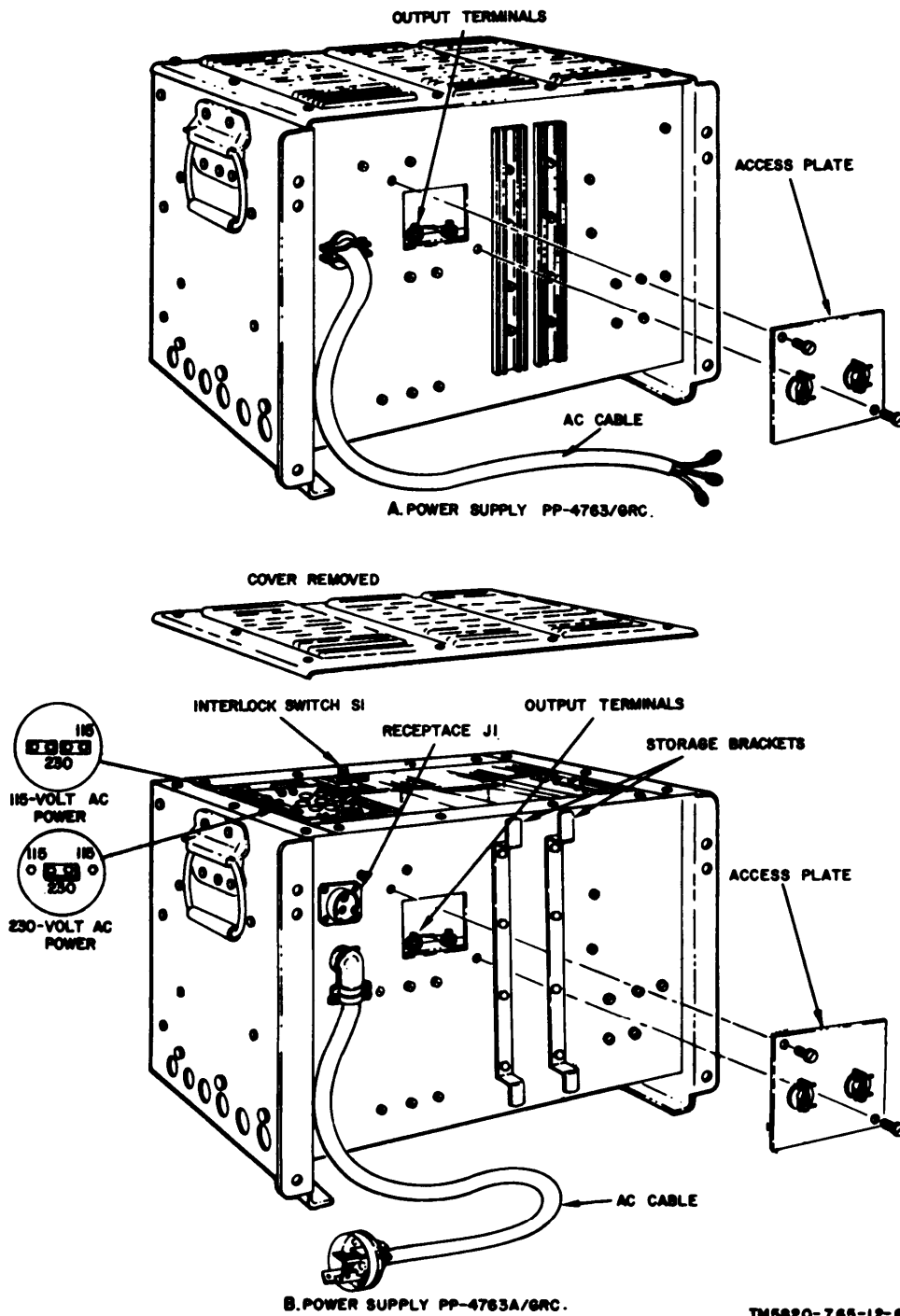

Figure 2-2. Installation connections.

## Section III. OPERATION

### 2-5. Operating Controls and Indicators

(fig. 2-3)

<i>Control or Indicator</i>	<i>Function</i>
AC ON-OFF switch (two-position toggle).	Serves dual function: ON-OFF switch for normal operation, and protective circuit breaker if operating current load exceeds safe current load.
Output current meter M2.	Indicates power supply output current.
Output voltage meter M1.	Indicates power supply dc output voltage.
Dc voltage adjust control.	Permits varying output voltage of power supply from 27 to 29 volts.

### 2-6. Preliminary Operating Procedure

**Caution:** A continuous flow of air through the power supply is necessary during operation to prevent damage because of overheating. Do not obstruct the flow of air through the louvers on the underside or the top of the equipment. If the fan fails to operate, do not continue operation of the equipment.

After performing the procedures given in paragraph 2-4, proceed as follows:

a. Place the AC ON-OFF switch to ON and read the output voltage as indicated on output voltage meter M1 (para 2-5).

b. Remove the ADJUST access plate on the front panel (fig. 2-3).

c. With a screwdriver, turn the shaft of the dc voltage adjust control until the output voltage meter M1 indicates the desired output voltage.

d. Check output current meter M2 indication. Output current should not exceed 50 amperes.

e. Place the AC ON-OFF switch at OFF and replace the ADJUST access plate on the front panel.

### 2-7. Operating Procedure

a. To operate the power supply, place the AC ON-OFF switch at ON.

b. Check the output voltage at intervals during operation of the power supply. When necessary, adjust the dc voltage adjust control to maintain the desired output voltage.

### 2-8. Stopping Procedure

Place the AC ON-OFF switch at OFF.



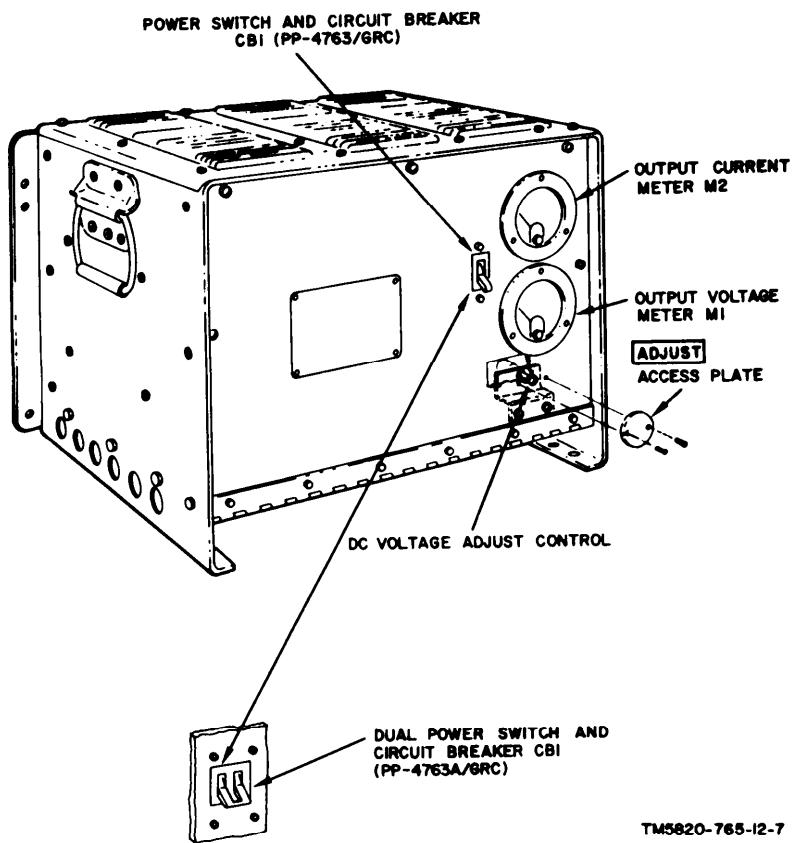

Figure 2-3. Front panel controls and indicators.

## CHAPTER 3

### OPERATOR'S MAINTENANCE

---

#### 3-1. Scope of Operator's Maintenance

The maintenance duties assigned to the operator of the power supply are listed below together with a reference to paragraphs covering the specific maintenance function.

- a. Operator's daily preventive maintenance checks and services chart (para 3-5).
- b. Operator's weekly preventive maintenance checks and services chart (para 3-6).
- c. Cleaning (para 3-7).

#### 3-2. Materials Required

- a. Cleaning compound (FSN 7930-395-9542).
- b. Cleaning cloth.

#### 3-3. Operator's Preventive Maintenance

Preventive maintenance is the systematic care, servicing, and inspection of equipment to prevent the occurrence of trouble, reduce downtime, and assure that the equipment is serviceable.

a. *Systematic Care.* The procedures given in paragraphs 3-5, 3-6, and 3-7 cover routine systematic care and cleaning essential to the proper upkeep of the power supply.

b. *Preventive Maintenance Check and Services.* The preventive maintenance checks and services charts (para 3-5 and 3-6) outline

functions to be performed at specific intervals. These checks and services are to maintain Army electronic equipment in a combat-serviceable condition; that is, in good general (physical) condition and in good operating condition. To assist operators in maintaining combat serviceability, the chart indicates what to check, how to check, and the normal indications; the *References* column lists the illustrations, paragraphs, or manuals that contain detailed repair or replacement procedures. If the defect cannot be remedied by the operator, a higher category of maintenance or repair is required. Records and reports of these checks and services must be made in accordance with the requirements set forth in TM 38-750.

#### 3-4. Operator's Preventive Maintenance Checks and Services Periods

Paragraph 3-5 specifies checks and services that must be accomplished daily, or under the conditions listed below.

- a. Before the power supply is put into operation.
- b. When the power supply initially is installed.
- c. When the power supply is reinstalled after removal for any reason.
- d. At least once each week if the power supply is maintained in a standby condition.

#### 3-5. Operator's Daily Preventive Maintenance Checks and Services Chart

##### *Warnings:*

1. Be careful when working on the 115- or 230-volt ac line connections. Serious injury or DEATH may result from contact with these terminals.
2. Low-voltage, high-amperage current is present at output connections and at connections inside equipment. Do not touch connections or remove cabinet cover until equipment is removed from power source. Reenergize power supply before performing any maintenance.

<b>Sequence No.</b>	<b>Item to be inspected</b>	<b>Procedure</b>	<b>References</b>
1	Completeness -----	Check to see that equipment is complete.	Appx B.
2	Exterior surfaces -----	Clean exterior surfaces, including panel and meter glasses. Check both meter glasses for cracks.	Para 3-7.
3	Operation -----	Operate equipment. Output voltage and output current meters should indicate output voltage and output current, respectively.	Para 2-6 and 2-7.

### 3-6. Operator's Weekly Preventive Maintenance Checks and Service Chart

#### *Warnings:*

1. Be careful when working on the 115-or 230-volt ac line connections Serious injury or DEATH may result from contact with these terminals.

2. Low-voltage high-amperage current is present at output connections and at connections inside equipment. Do not touch connections or remove cabinet cover until equipment is removed from power source. Reenergize power supply before performing any maintenance.

<b>Sequence No.</b>	<b>Item to be inspected</b>	<b>Procedure</b>	<b>References</b>
1	Cable -----	Inspect cable for frayed, chafed, or cracked insulation. Replace any connector that is broken, arced, or worn excessively.	Refer to higher category of maintenance.
2	Metal surfaces -----	Inspect exposed metal surface for rust or corrosion. Clean and touchup paint as required.	Refer to higher category of maintenance.

### 3-7. Cleaning

The exterior surfaces of the power supply should be free of dust, dirt, grease, and fungus.

a. Remove dust and loose dirt with a clean, soft cloth.

**Warning:** Prolonged breathing of cleaning compound is dangerous; make sure adequate ventilation is provided. Cleaning compound is flammable; do not use near a flame. Avoid contact with the skin; wash off any that spills on the hands.

b. Remove grease, fungus, and ground-in dirt

from the case; use a cloth dampened (not wet) with the cleaning compound.

c. Remove dust or dirt from the plug and jack with a cotton swab stick lightly dampened with the cleaning compound.

**Caution:** Do not press on the meter face (glass) when cleaning; the meter may become damaged.

d. Clean the front panel, meters, and knob; use a soft, clean cloth. If dirt is difficult to remove, dampen the cloth with water; mild soap may be used for more effective cleaning.

## CHAPTER 4

### ORGANIZATIONAL MAINTENANCE

---

#### 4-1. Scope of Organizational Maintenance

*a.* This chapter contains instructions covering organizational maintenance for the power supply. It includes instructions for performing preventive and periodic maintenance services and repair functions to be accomplished by the organizational repairman.

*b.* Organizational maintenance of the power supply includes:

- (1) Preventive maintenance checks and services (para 4-4).
- (2) Touchup painting (para 4-5).

#### 4-2. Test Equipment, Tools, and Materials Required

The test equipment, tools, and materials required for organizational maintenance of the power supply are listed below.

*a. Test Equipment.* Multimeter AN/URM-106 (TM 11-6625-208-12) .

*b. Tool.* Tool kit Electronic Equipment TK-101/G (SM 11-4-5180-R13).

*c. Materials.*

- (1) Cleaning compound (Federal stock No. 7930-395-9542) .
- (2) Cleaning cloth.

(3) Fine sandpaper (supplied with Tool Kit, Electronic Equipment TK-101/G).

(4) Cotton swab sticks.

#### 4-3. Organization Monthly Maintenance

Perform the maintenance functions indicated in the organizational monthly preventive maintenance checks and services chart (para 4-4) once each month. A month is defined as approximately 30 calendar days of 8 hour-per-day operation. If the equipment is operation 16 hours a day, the monthly preventive maintenance checks and services should be performed at 15-day intervals. Adjustment of the maintenance interval must be made to compensate for any unusual operating conditions. Equipment maintained in a standby (ready for immediate operation) condition must have monthly preventive maintenance checks and services performed on it. Equipment in limited storage (requires service before operation) does not require monthly preventive maintenance. The daily and weekly periodic services constitute a part of the monthly preventive maintenance checks and services and must be performed concurrently. All deficiencies or shortcomings should be recorded in accordance with the requirements of TM 38-750. Perform all the checks and services listed in the monthly preventive maintenance checks and services chart (para 4-4) in the sequence listed.

#### 4-4. Organizational Monthly Preventive Maintenance Checks and Service Chart

##### *Warning:*

1. Be careful when working on the 115- or 230-volt ac line connections. Serious injury or DEATH may result from contact with these terminals.

2. Low-voltage, high-amperage current is present at output connections and at connections inside the equipment. Do not touch connetions or remove cabinet cover until equipment is removed from power source. Deenergize the power supply before performing any maintenance

<b>Sequence No.</b>	<b>Item to be inspected</b>	<b>Procedure</b>	<b>References</b>
1.	Installation-----	Check to see that equipment is complete.	Appx B.
2	Preservation-----	Check all surfaces for evidence of fungus. Remove rust and corrosion and spot-paint bare spots.	Para 4-6.
3	Publications-----	Check to see that all publications are complete, serviceable and current	DA Pam 310-4.
4	Modifications-----	Check DA Pam 310-7 to determine if new applicable MWO'S have been published. AU URGENT MWO'S must be applied immediately. All NORMAL MWO'S must be scheduled.	DA Pam 310-7.
5	Connections and cables-----	Check to be sure that connectors are intact, clean, and tight-fitting, and cable is in good condition, free from cracks <i>or</i> deteriorated insulation. Check cables for continuity.	
6	ACON-OFF switch-----	Check that mechanical operation of AC ON-OFF switch is smooth and free from internal and external binding.	
7	Hardware-----	Check to see that no parts or hardware, such as bolts, nuts, and screws are missing.	
8	Fan-----	Check to see that fan and interior of power supply is clean.	

#### 4-5. Touchup Painting

Remove rust and corrosion from metal surfaces by lightly sanding them with fine sandpaper. Brush two thin coats of paint (Enamel, Semigloss, olive Drab FSN 8010-844-8088) on

the bare metal to protect it from further corrosion. Refer to the applicable cleaning and refinishing practices specified in TB SIG 364 and the painting supplies available for field use in SB 11-573.

**CHAPTER 5**  
**SHIPMENT AND LIMITED STORAGE AND DEMOLITION**  
**TO PREVENT ENEMY USE**

---

**Section I. SHIPMENT AND LIMITED STORAGE**

**5-1. Dissassembly and Repacking of Equipment**

Prepare the power supply for repacking for shipment and limited storage as follows:

- a. Place the AC ON-OFF switch at OFF.
- b. Remove the two dc leads that connect the power supply output to other equipment.
- c. Disconnect the ac cable.
- d. Wrap the technical manual in wrapping paper and secure it with pressure-sensitive tape.

e. Fasten the packages that contain the cable assembly and the technical manuals to the power supply (fig. 2-1).

**5-2. Repacking**

Normally, repackaging the power supply for shipment or limited storage will be performed at a packaging facility or by a repackaging team. If emergency packaging is required, select the materials from those listed in SB 38-100. Package the equipment in accordance with the original packaging (para 2-1) so far as possible with the available materials.

**Section II. DEMOLITION OF MATERIEL TO PREVENT ENEMY USE**

**5-3. Authority for Demolition**

Demolition of the equipment will be accomplished only upon order of the commander. Use the destruction procedures outlined in paragraph 5-4 to prevent further use of the equipment

**5-4. Methods of Destruction**

The tactical situation and time available will determine the method to be used when destruction of equipment is ordered. In most cases, it is preferable to completely demolish some portions of the equipment rather than partially destroy all the equipment components. Spare parts should be destroyed with the same thoroughness as the basic equipment.

a. *Smash.* Smash the electronic parts, meters and controls, and cabinet.

b. *Cut.* Cut the wiring and cabling of the power supply.

c. *Burn.* Burn the spare parts and the technical manuals covering the equipment.

**Warning: Be extremely careful with explosives and incendiary devices. Use these items only when the need is urgent.**

d. *Explode.* If explosives are necessary, use grenades, TNT, or firearms.

e. *Dispose.* Bury or scatter destroyed parts, including spare parts.

## APPENDIX A

### REFERENCES

---

The following is a list of applicable references that are available to the operator and organisational repairman of the power supply.

- AR 55-38 ----- Report of Transportation Discrepancies in Shipments (Reports Control Symbol MTMTS-54).
- AR 700-58 ----- Report of Packaging and Handling Deficiencies (Reports Control Symbol AMC-137) .
- DA Pam 310-4 ----- Index of Technical Manuals, Technical Bulletins, Supply Manuals (types 7, 8, and 9), Supply Bulletins, and Lubrication Orders.
- DA Pam 310-7 ----- U.S. Army Equipment Index of Modification Work Orders.
- SB 11-578----- Painting and Preservation Supplies Available for Field Use for Electronics Command Equipment.
- SB 38-100 ----- Preservation, Packaging, and Packing Materials, Supplies, and Equipment Used by the Army.
- SM 11-4-5180-R13 -- Tool Kit, Electronics Equipment TK-101/G.
- TB SIG 364----- Field Instructions for Painting and Preserving Electronics Command Equipment.
- TM 11-6625-203-12 ----- Operator and Organizational Maintenance Manual; Multimeter AN/URM-106, Including Multimeter ME-77/U.
- TM 38-750 ----- Army Equipment Record Procedures.

## APPENDIX B

### BASIC ISSUE ITEMS

---

#### Section I. INTRODUCTION

##### **B-1. Scope**

This appendix lists items comprising an operable equipment and those required for installation, operation, or operator's maintenance for Power supply PP-4763/GRC and PP-4763A/GRC.

##### **B-2. Explanation of Columns**

The following is a list of explanations of columns in section II.

*a. Source, Maintenance, and Recoverability Code (SMR) Column.* Not used.

*b. Federal Stock Number Column.* This column indicates the Federal stock number for the item.

*c. Description Column.* This column includes the Federal item name and any additional description of the item which may be required.

*d. Unit of Measure Column.* The unit used as a basis of measure (e.g., ea, pr, ft, yd, etc.) is given in this column.

*e. Quantity Incorporated in Unit Column.* The quantity of the item used in the equipment is given in this column.

*f. Quantity Furnished unit Equipment Column.* This column lists the quantity of the item supplied for initial operation of the equipment and/or the quantities authorized to be kept on hand by the operator for maintenance of the equipment.

*g. Illustrations Column.*

*(1) Figure number (a).* The number of the illustration on which the item is shown is indicated in this column.

*(2) Item No. or reference designation (b).* Not used.



## SECTION "BASIC ISSUE ITEMS

(1) SIR CODE	(2) FEDERAL STOCK NUMBER	(3) DESCRIPTION  Reference Number & Mfr Code  USABLE ON CODE	(4) UNIT OF MEAS	(5) QTY INC IN UNIT	(6) QTY FURN WITH EQUIP	(7) ILLUSTRATIONS	
						(a) FIG. NO.	(b) ITEM NO. OR REFERENCE DESIGNATION
	5820-937-7690	<p>POWER SUPPLY PP-4763/GRC (This item is nonexpendable)</p> <p>POWER SUPPLY PP-4763A/GRC (This item is nonexpendable)</p> <p>TECHNICAL MANUAL TM 11-5820-765-12</p> <p>Requisition through pinpoint account number if assigned; otherwise through nearest Adjutant General facility.</p> <p>A quantity of one technical manual is packed with each equipment. Where a valid need exists, additional copies may be requisitioned and kept on hand.</p> <p>NO PART AUTHORIZED OPERATOR/CREW</p> <p>ACCESSORIES, TOOLS AND TEST EQUIPMENT</p> <p>NO ACCESSORIES, TOOLS, OR TEST EQUIPMENT ARE TO BE ISSUED WITH THIS EQUIPMENT</p> <p>NO BASIC ISSUE ITEMS ARE MOUNTED IN OR ON THIS EQUIPMENT</p>	ea			1-1	
			ea			I-1	
			ea	1		1-1	

# APPENDIX C

## MAINTENANCE ALLOCATION

---

### Section I. INTRODUCTION

#### C-1. General

This appendix provides a summary of the maintenance operations covered in the equipment literature for Power supply PP-4763/GRC and PP-4763A/GRC. It authorizes categories of maintenance for specific maintenance functions on repairable items and components and the tools and equipment required to perform each function. This appendix may be used as an aid in planning maintenance operations.

#### C-2. Explanation of Format for Maintenance Allocation Chart

*a. Group Number.* Not used.

*b. Component Assembly Nomenclature.* This column lists the item names of component units, assemblies, subassemblies, and modules on which maintenance is authorized.

*c. Maintenance Function.* This column indicates the maintenance category at which performance of the specific maintenance function is authorized. Authorization to perform a function at higher categories. The codes used represent the various maintenance categories as follows:

<b>Code</b>	<b>Maintenance category</b>
C	Operator/Crew
O	Organizational Maintenance
F	Direct Support Maintenance
H	General Support Maintenance
D	Depot Maintenance

*d. Tools and Equipment.* The numbers appearing in this column refer to specific tools and equipment which are identified by these numbers in section III.

*e. Remarks.* Self explanatory.

#### C-3. Explanation of Format for Tool and Test Equipment Requirements

The columns in the tool and test equipment requirements chart are as follows:

*a. Tools and Equipment.* The numbers in this column coincide with the numbers used in the tools and equipment column of the MAC. The numbers indicate the applicable tool for the maintenance function.

*b. Maintenance Category.* The codes in this column indicate the maintenance category normally allocated the facility.

*c. Nomenclature.* This column lists tools, test and maintenance equipment required to perform the maintenance functions

*d. Federal Stock Number.* This column lists the Federal stock number.

*e. Tool Number.* Not used

## SECTION II. MAINTENANCE ALLOCATION CHART

GROUP NUMBER	COMPONENT ASSEMBLY Nomenclature	MAINTENANCE FUNCTIONS										TOOLS AND EQUIPMENT	REMARKS	
		INSPECT	TEST	SERVICE	ADJUST	ALIGN	CALIBRATE	INSTALL	REPLACE	REPAIR	OVERHAUL			REBUILD
	POWER SUPPLY PP-4763/GRC AND PP-4763A/GRC	0	0 F H		0			0			0 F H		1 5 thru 8 5 thru 9 2 2 2 3,4 3,4 3 thru 10	Operational test and circuit continuity check only. Diodes, meters, rectifiers and capacitors checks only. All test Voltage adjustment Repair by replacement of knobs and other external repairs. Repair circuit boards by replacement only. All repairs Depot may use any other equipment necessary to overhaul this equipment

## SECTION III. TOOL AND TEST EQUIPMENT REQUIREMENTS

TOOL AND TEST EQUIPMENT REQUIREMENTS				
TOOLS AND EQUIPMENT	MAINTENANCE CATEGORY	NOMENCLATURE	FEDERAL STOCK NUMBER	TOOL NUMBER
1	O	PP-4763/GRC & PP-4763A/GRC (cont.) MULTIMETER AM/URM-105	6625-581-2036	
2	O	TOOL KIT, ELECTRONIC EQUIPMENT TX-101/G	5180-064-5178	
3	F,H,D	TOOL KIT, ELECTRONIC EQUIPMENT TX-100/G	5180-605-0079	
4	F,H,D	TOOL KIT, ELECTRONIC EQUIPMENT TX-105/G	5180-610-8177	
5	F,H,D	MULTIMETER TS-352B/U	6625-242-5023	
6	F,H,D	VOLTMETER AM/USM-98A	6625-753-2115	
7	F,H,D	VOLTMETER, ELECTRONIC AM/URM-145	6625-973-3986	
8	F,H,D	TRANSFORMER, VARIABLE POWER TP-171/USM	5950-503-0632	
9	H,D	OSCILLOSCOPE AM/USM-140	6625-987-6603	
10	D	KNIFE SWITCH		

By Order of the Secretary of the Army:

Official:

KENNETH G. WICKHAM,  
*Major General, United States Army,  
The Adjutant General*

WILLIAM C. WESTMORELAND,  
*General, United States Army,  
Chief of Staff.*

Distribution:

To be distributed in accordance with DA Form 12-61 Organization maintenance literature requirements for AN/GRC-106, AN/GRC-122, AN/GRC-142 and AN/VSC-2 radio sets.

☆ U. S. GOVERNMENT PRINTING OFFICE : 1987- 201-421 (70877)

RECOMMENDED CHANGES TO EQUIPMENT TECHNICAL PUBLICATIONS



THEN...JOT DOWN THE  
DOPE ABOUT IT ON THIS FORM.  
CAREFULLY TEAR IT OUT, FOLD IT  
AND DROP IT IN THE MAIL.

SOMETHING WRONG WITH PUBLICATION

FROM: (PRINT YOUR UNIT'S COMPLETE ADDRESS)

DATE SENT

PUBLICATION NUMBER

PUBLICATION DATE

PUBLICATION TITLE

BE EXACT PIN-POINT WHERE IT IS

PAGE  
NO.

PARA-  
GRAPH

FIGURE  
NO.

TABLE  
NO.

IN THIS SPACE, TELL WHAT IS WRONG  
AND WHAT SHOULD BE DONE ABOUT IT.

TEAR ALONG PERFORATED LINE

PRINTED NAME, GRADE OR TITLE AND TELEPHONE NUMBER

SIGN HERE

